

Electromagnetic Lock Installation Instructions

※Dimensions

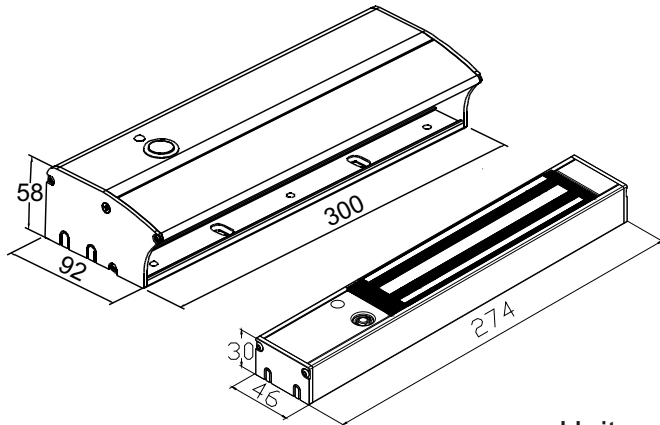

Unit: mm

※Accessories

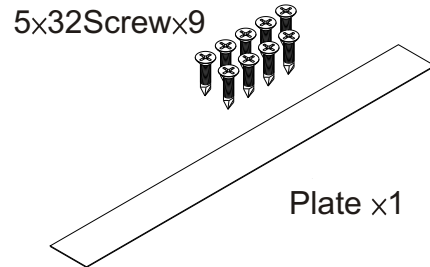

※Features

1. Suitable for in-swing door or 90° doors
2. Built-in push button and power indicator light.
Adjustable door opening time (0~9 seconds.)
3. Build-in delay time and lock monitor output.
4. Armature with handle design.
5. Standalone operation when power is on and it does not need to be controlled by proximity reader.
6. Install at the center of the door leaf to prevent deformation whenever it is locked or unlock.

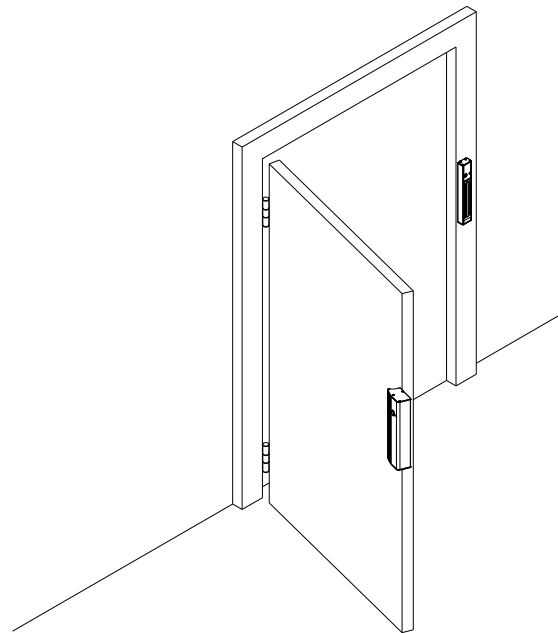

※Specifications

Item \ Model	EL-250	Notes
Power Supply	DC 12V / DC 24V	± 15%
Current	450mA / 12VDC 235mA / 24VDC	± 5%
Monitor Output	N.O / N.C	Hall Effect Sensor
Operation Delay Time	0 sec., 2.5sec., 5sec., 9sec.	
Application	Out-swing door and In-swing door	
Holding forces	600lbs	
Operation temperature	35°C ± 5°C (30°C room temperature)	
Warranty	The warranty is 1 years under normal circumstances	
Weight	3 kg	

※Control Panel

※Voltage and Delay Time Adjusting

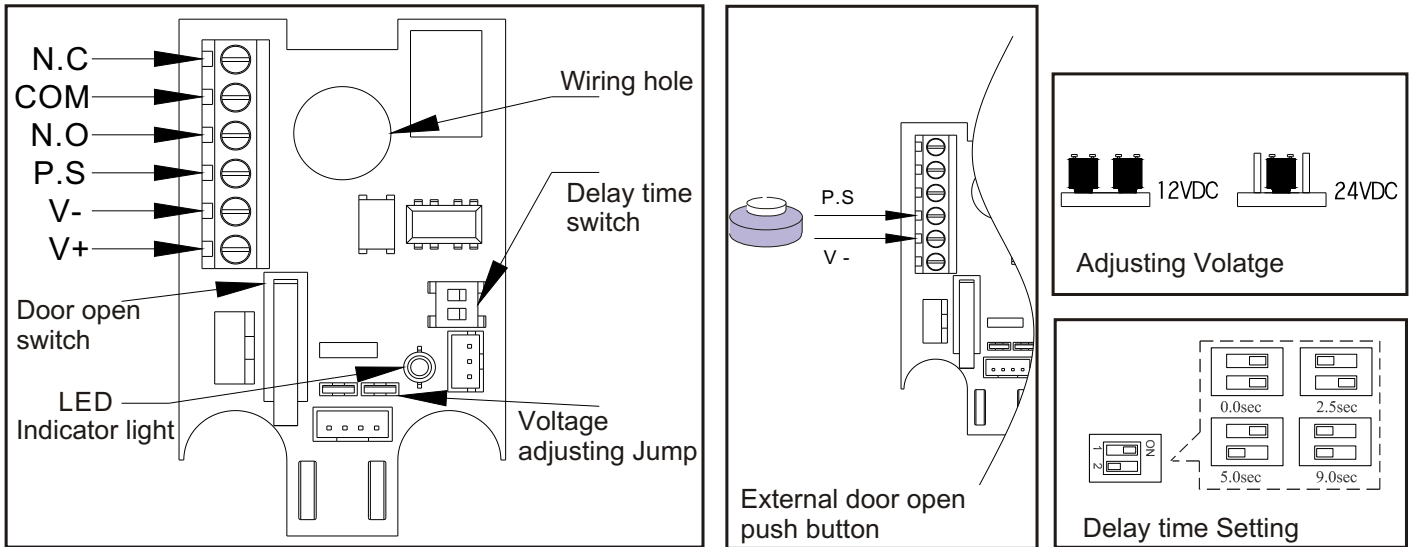

Attention

1. Door open buttons have both built-in and external inputs. Please use both V- and P.S. Points for external door open button. Both built-in and external door open buttons are able to be used at the same time. (Please refer to the diagram above).
2. Door Lock status (N.O/N.C) as Relay output. Maximum load of 1A@24VAC.
3. Indicator light is green when the door is locked, or else the door did not close tight.

Installation

Step 1:

Please stick the sticker on the desired mounting position (Please refer to Fig.1) and drill holes according to the sticker's indicated positions. Remove the sticker after drilling a hole for wiring.

Step 2:

Remove both sides of the lock's covers A and pull out the B. (Please refer to Fig.2- Fig.4)

Use screws to screw the body lock tight on the appropriate position. Place all covers back in order.

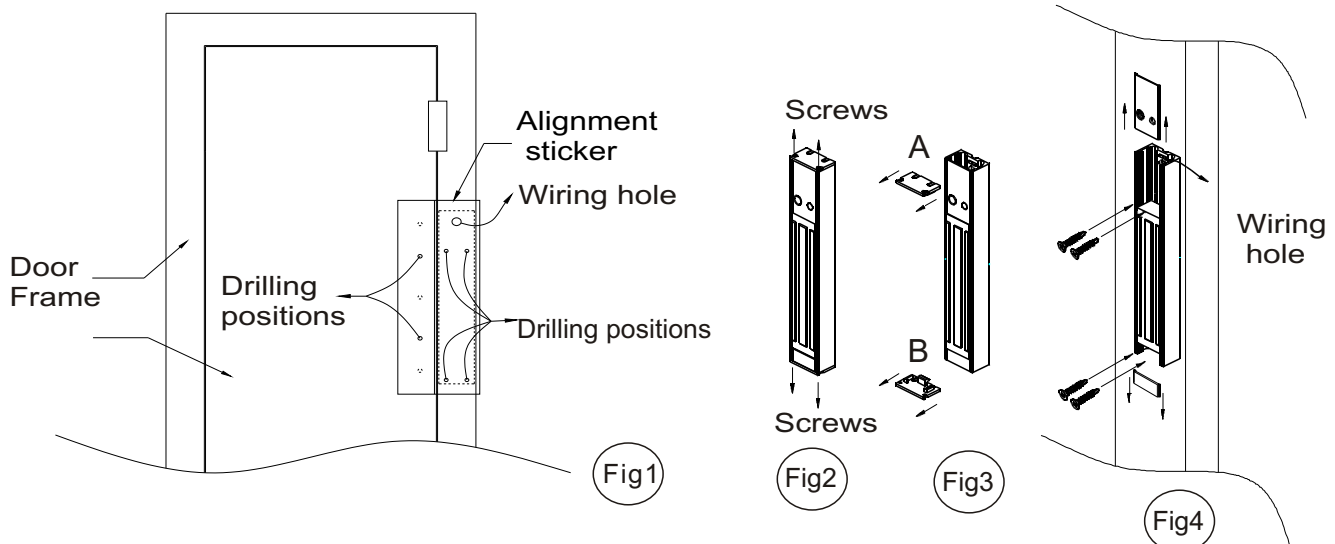

Step 3:

Remove the upper cover (C) of the handle and then the lower cover(C-1) by removing two screws (A-1 , B-1) to pull out plate(D).(Please refer to Fig5-Fig6)

Step 4:

Use two attached screws to screw the handle onto the appropriate position of the installation holes when D is pulled out.(Please refer to Fig 7) Do not screw tight as to adjust both handle and body lock positions well by closing the door for several times to make sure both of them are matched. Screw the remaining three screws when they are matched.

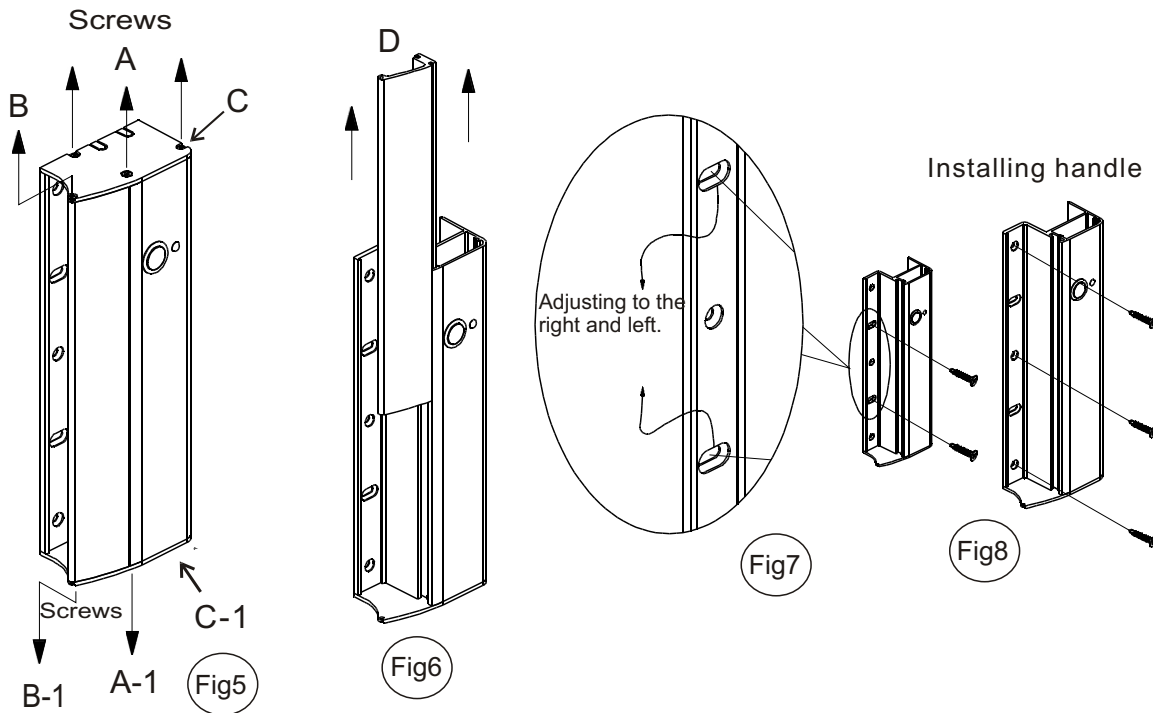

Step 5:

Slide plate(P) in when positioning and adjusting screws are tighten. Assemble the handle and its body's back in order.

Installation diagram

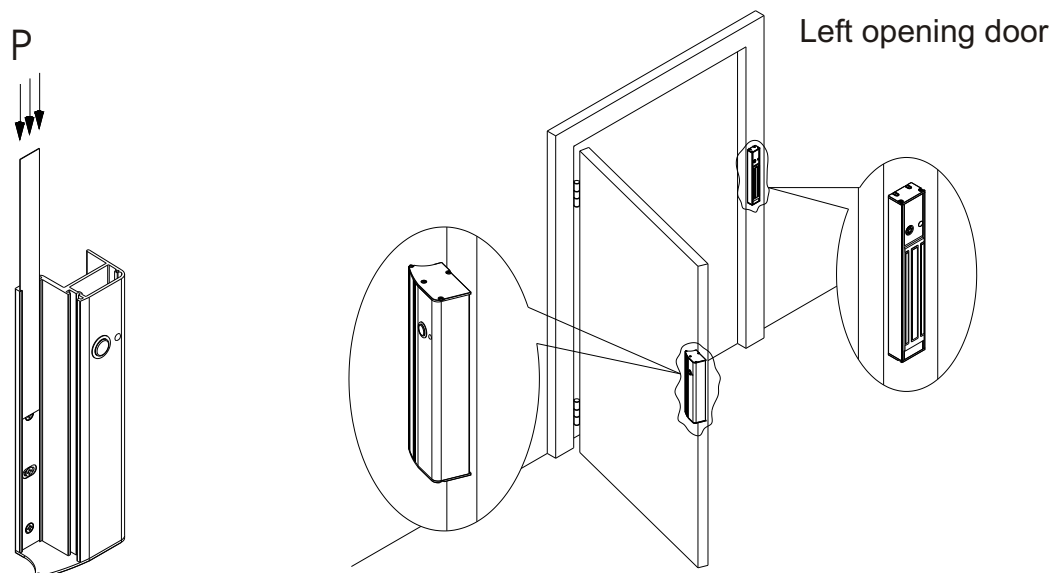

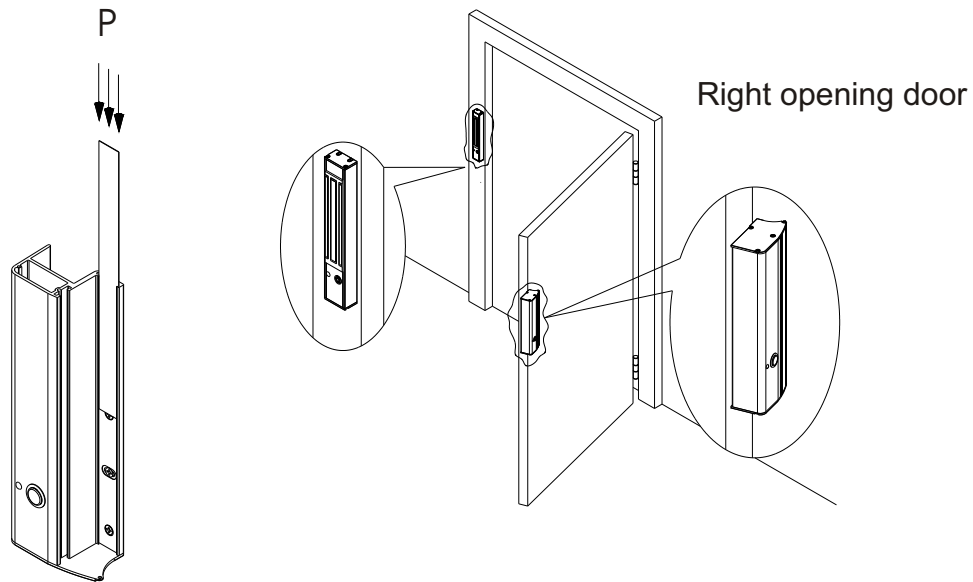

Optional plate

Optional EL-250P plate (thickness of 3.6mm) is available to achieve optimum height of both door frame and door leaf when the unit is installed.

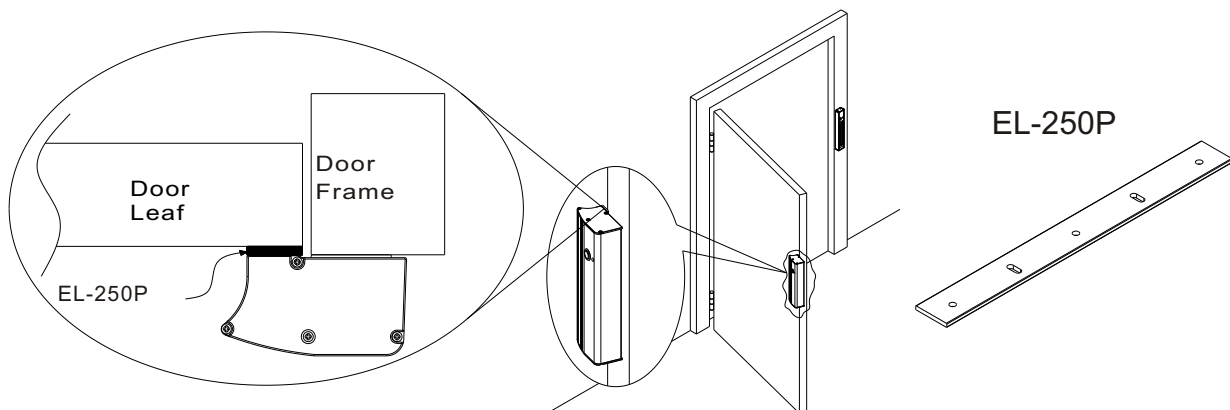

Q & A

◆	Door is not locked light.
	1. Check if the voltage is correct. 2. Check if the setting of voltage is correct. 3. Check if the magnetic lock and armature are engaged lightly.
◆	Indicator light is unable to show green light when door is closed.
	1. Check if the armature is mounted to the correct position.
	2. Check if the voltage is set correctly. Any dust or rust will affect the operation of the lock.
◆	Maintenance of the magnetic lock.
	1. Any dust or rust should be removed regularly.
	2. Lubricant should be apply on the magnetic lock to avoid any rust depending on the environment it is installed (such as at the seaside).